

Összeszerelési útmutató

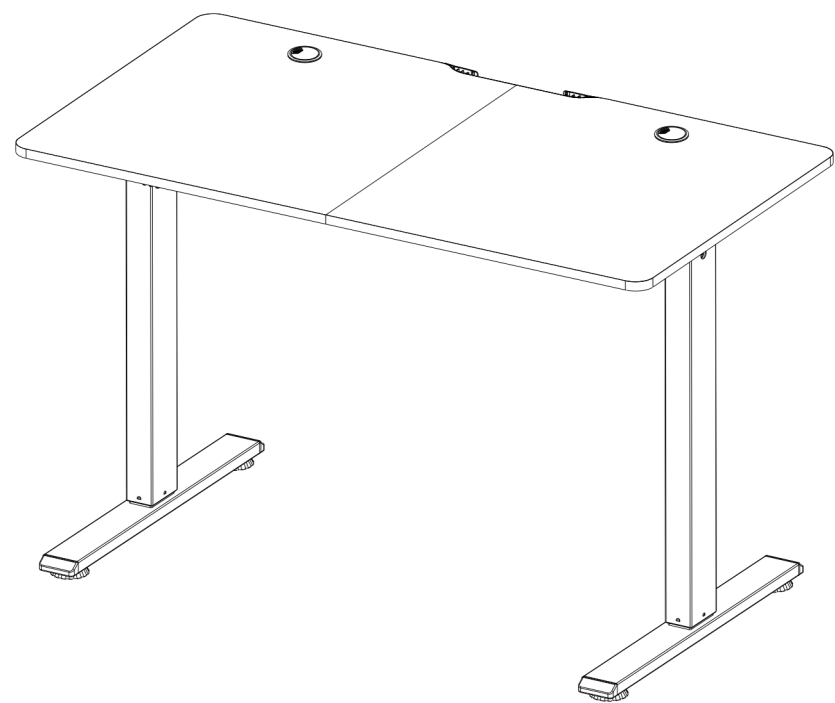

Tartozékok

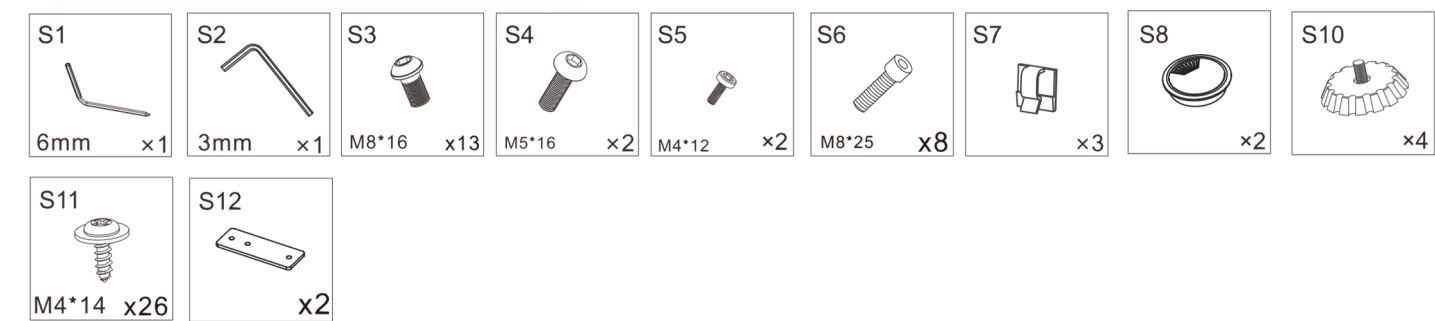

Alkatrészek

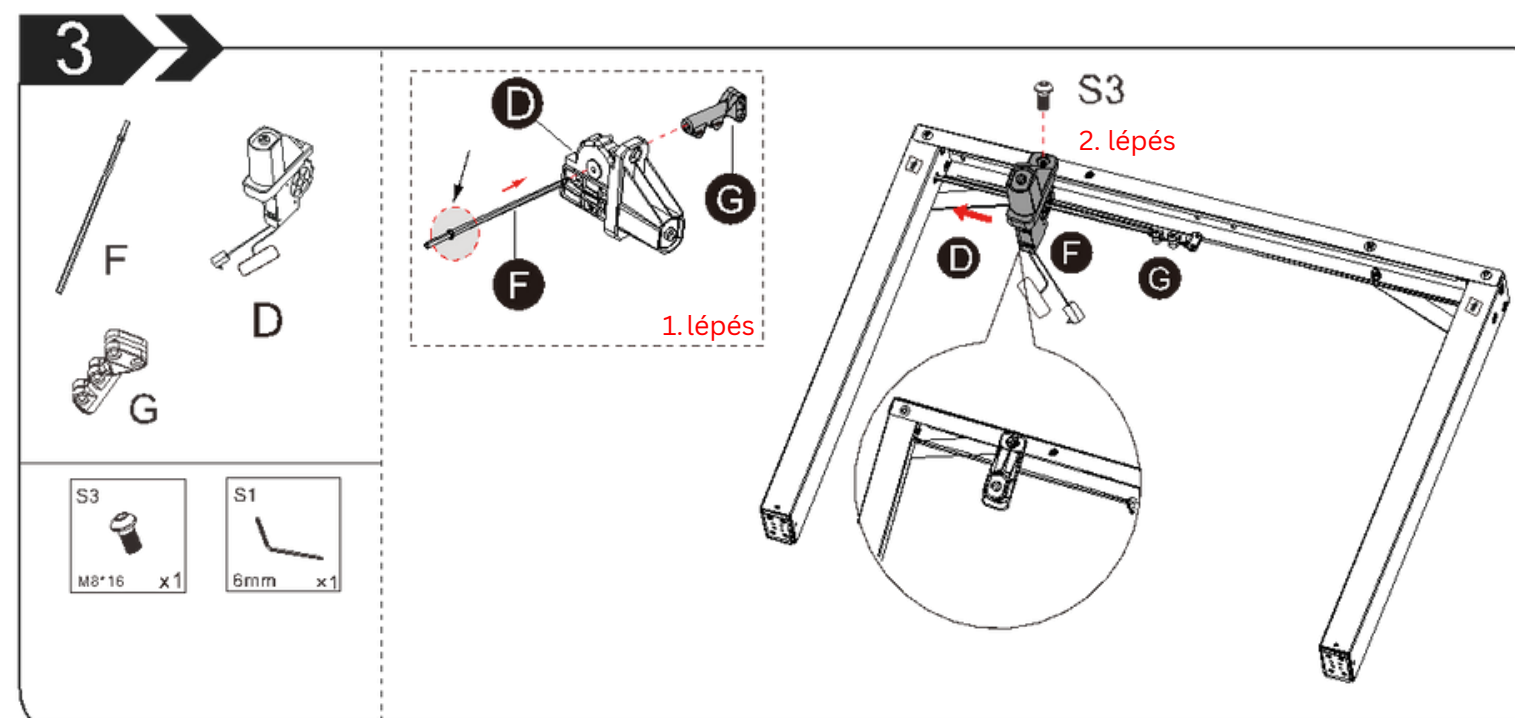
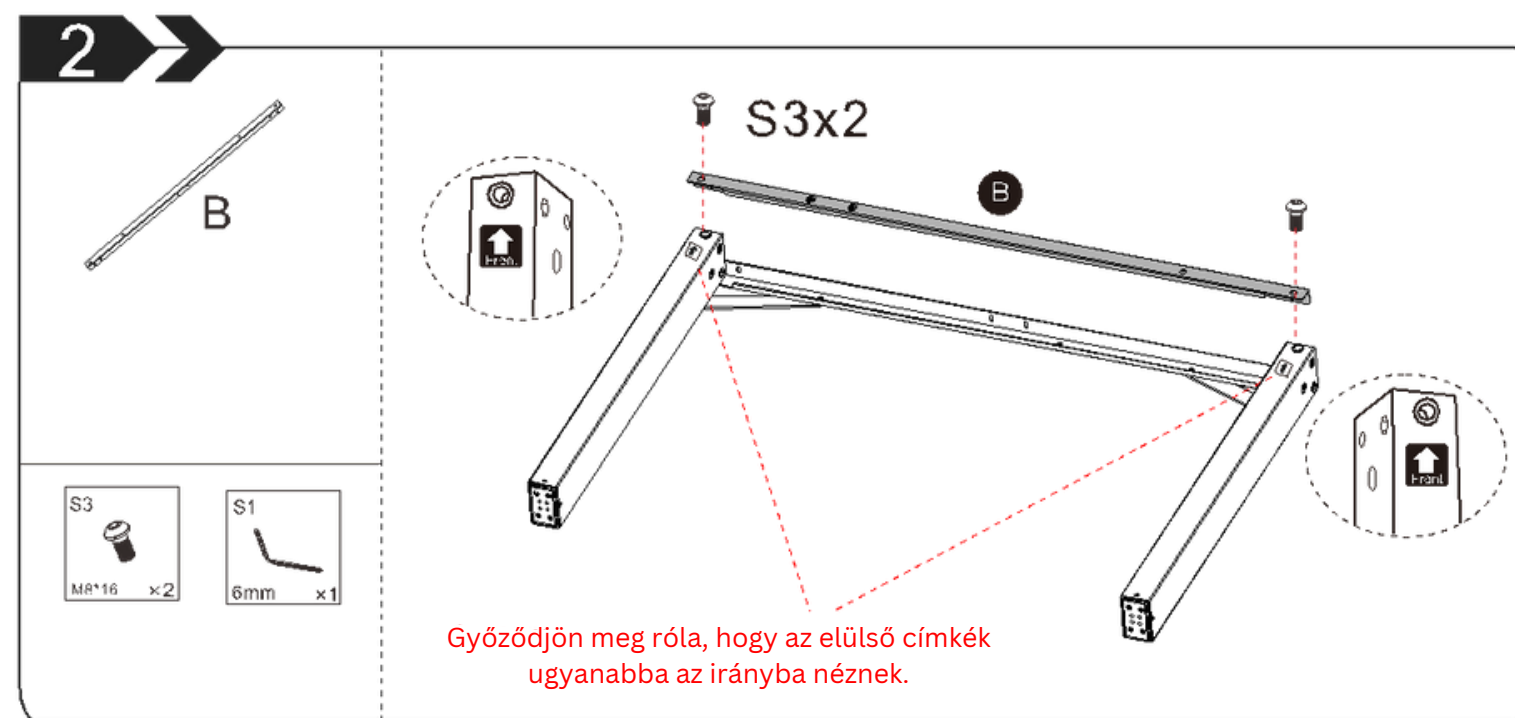
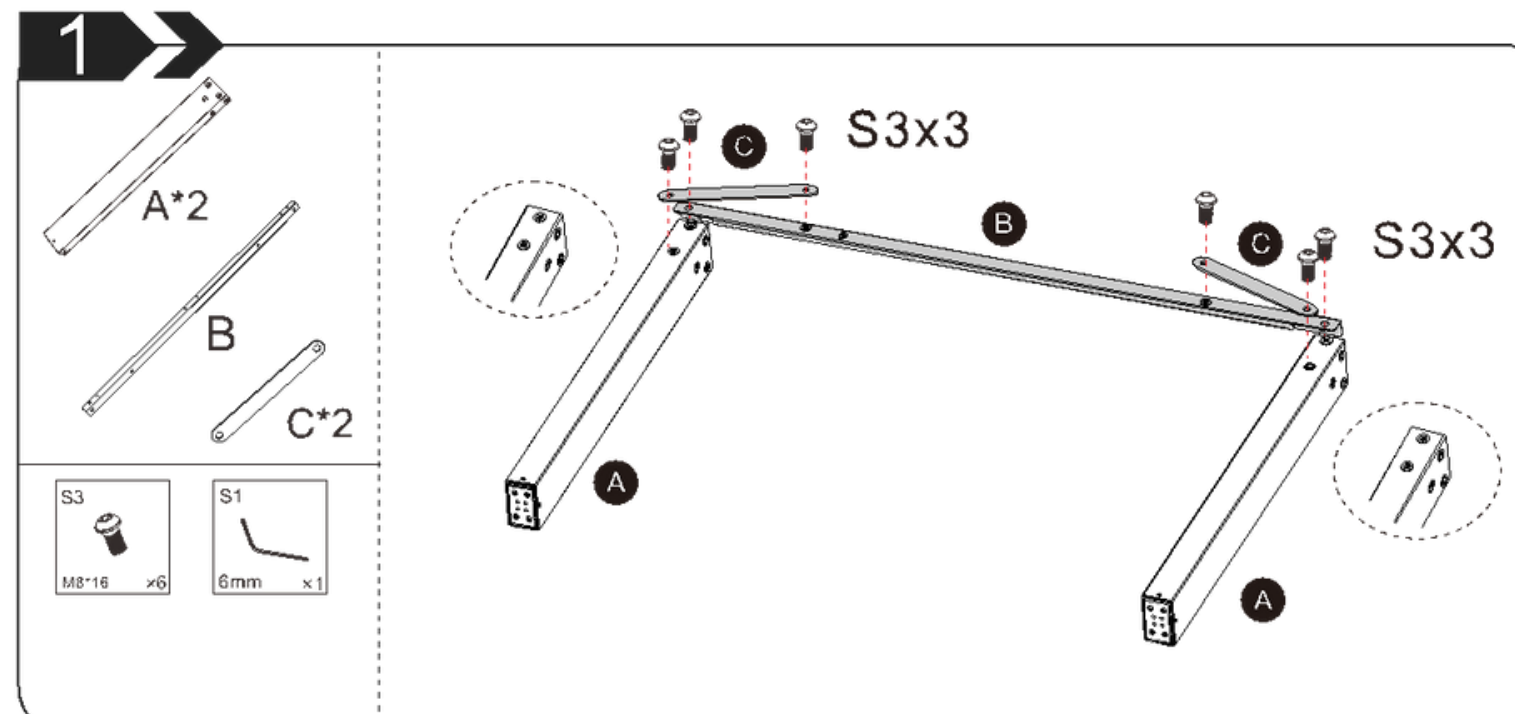
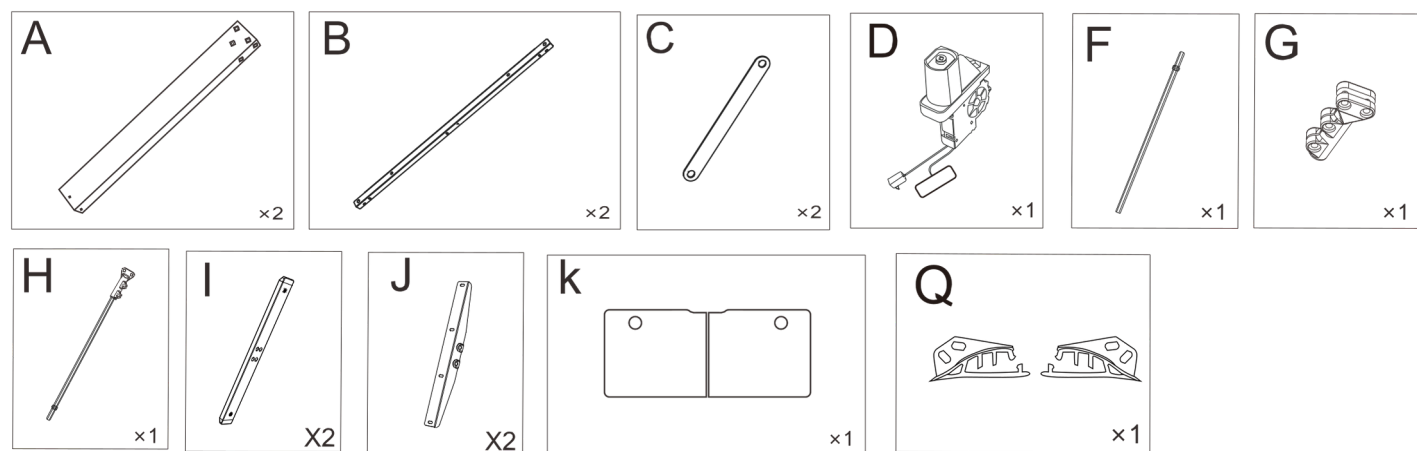

4

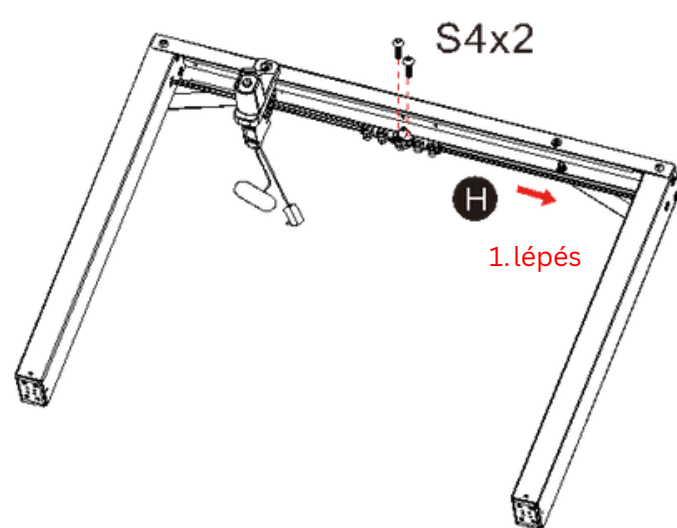
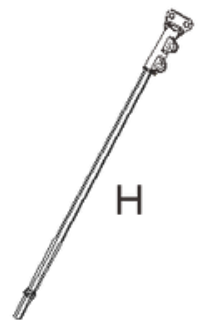

2. lépés

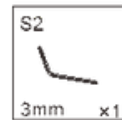
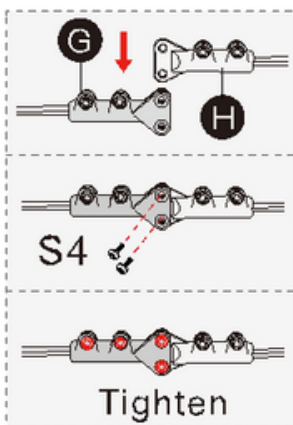

5

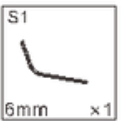
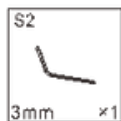
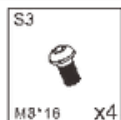
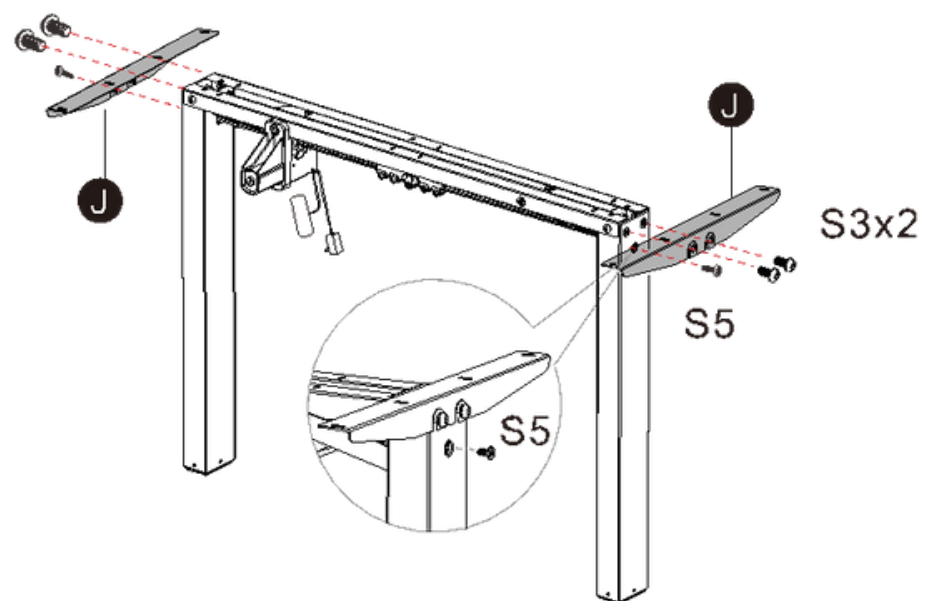
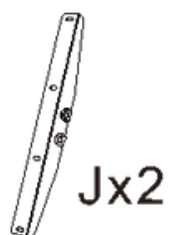

7



K



Q

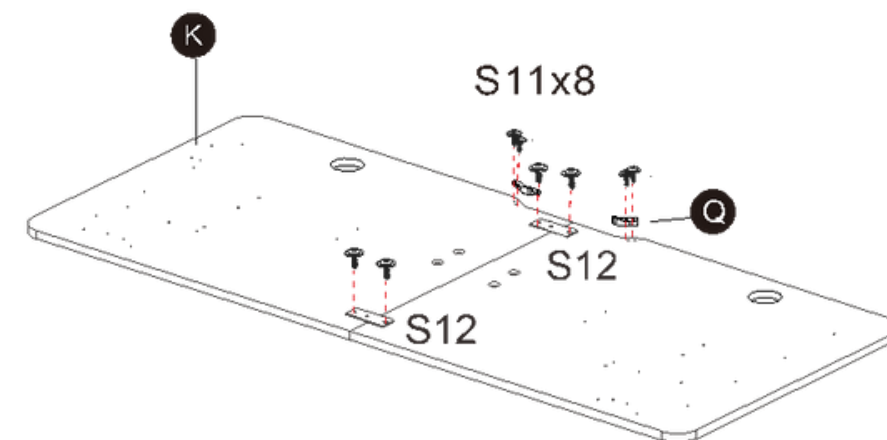
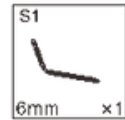
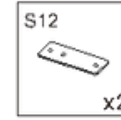
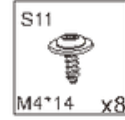

1. Kérjük, győződjön meg róla, hogy a két tábla egy vonalban van és hézagmentes.
2. majd húzza meg a csavarokat

8

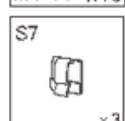
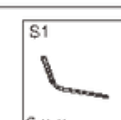
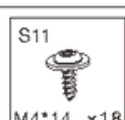
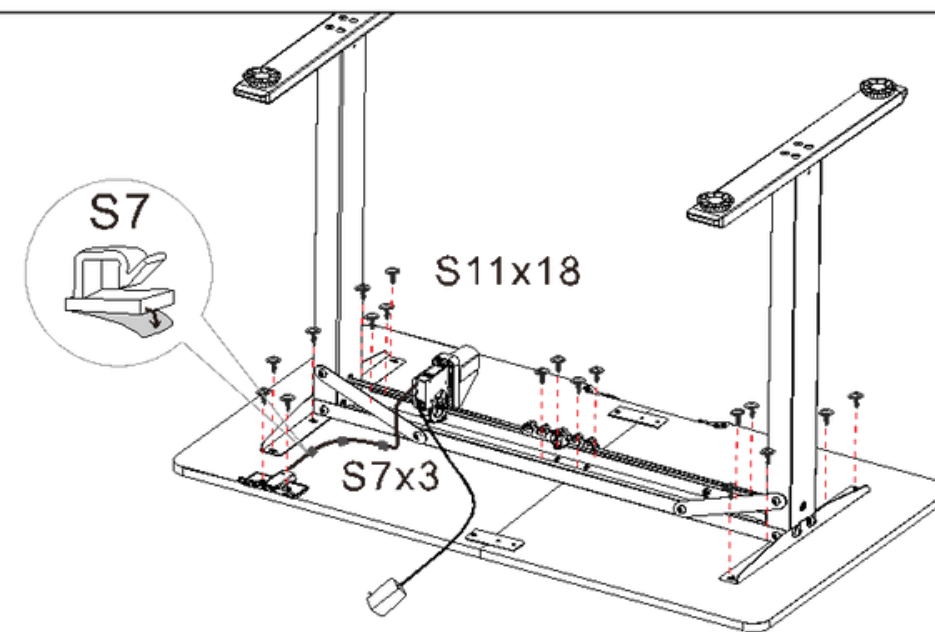

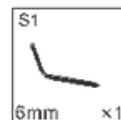
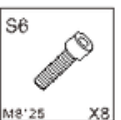
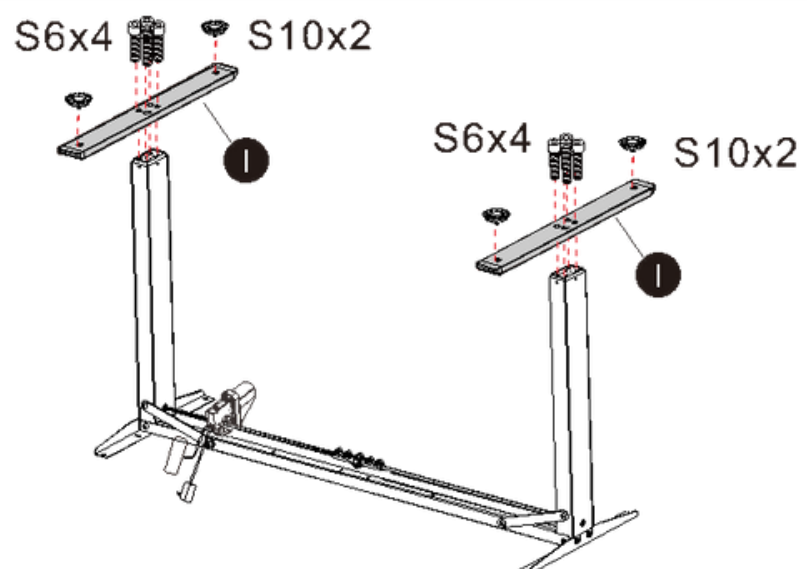
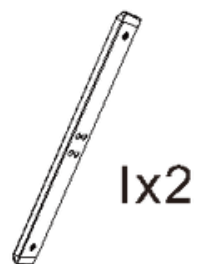

6

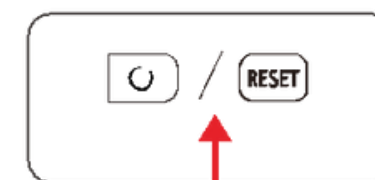
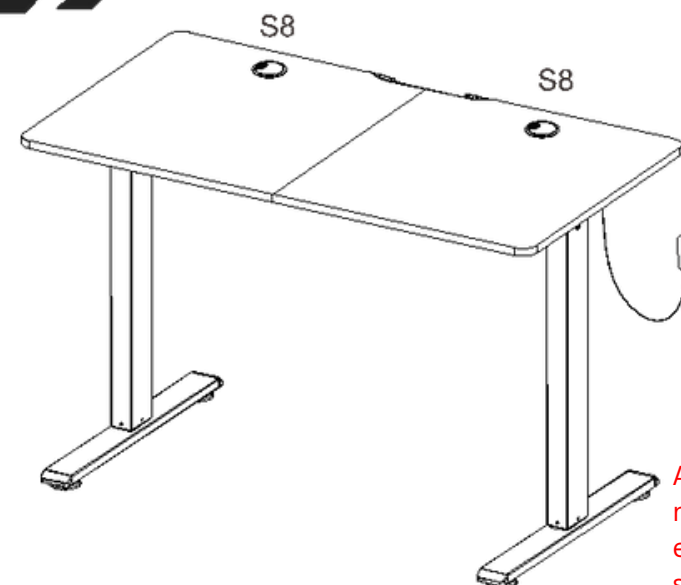

Ügyeljen arra, hogy az asztallábak függőlegesen álljanak az összekötő rúdhoz. És ezután húzza meg az összes csavart.

9



Az asztal összeszerelése után nyomja meg a  gombot az indításhoz.

Az asztal automatikusan a legalacsonyabb pontra esik, 3 másodpercig ott marad, majd a legmagasabb pontra emelkedik, és végül visszatér a kiindulási helyzetbe - sikeresen üzembe helyezte az asztalt.